



“Gheorghe Asachi” Technical University of Iasi, Romania



EFFICIENT DEGRADATION OF CLOFIBRIC ACID BY HETEROGENEOUS PHOTOCATALYTIC OXIDATION PROCESS

**Lidia Favier^{1*}, Lacramioara Rusu^{2*}, Andrei Ionut Simion^{2*}, Raluca Maria Hlihor^{3,4},
Mariana Liliana Pacala⁵, Adrian Augustyniak⁶**

¹Univ. Rennes, Ecole Nationale Supérieure de Chimie de Rennes, CNRS, ISCR – UMR6226, F-35000 Rennes, France,
11 Allée de Beaulieu, CS 50837, 35708 Rennes Cedex 7, France

²“Vasile Alecsandri” University of Bacau, Faculty of Engineering, Department of Chemical and Food Engineering,
157 Calea Marasesti, 600115 Bacau, Romania

³“Ion Ionescu de la Brad” University of Agricultural Sciences and Veterinary Medicine of Iasi, Faculty of Horticulture,
Department of Horticultural Technologies, 3 Mihail Sadoveanu Alley, 700490 Iasi, Romania

⁴“Gheorghe Asachi” Technical University of Iasi, “Cristofor Simionescu” Faculty of Chemical Engineering and Environmental
Protection, Department of Environmental Engineering and Management, 73 Prof. Dr. Docent D. Mangeron Str.,
700050 Iasi, Romania

⁵“Lucian Blaga” University of Sibiu, Faculty of Agricultural Science, Food Industry and Environmental Protection,
7-9 Dr. I. Ratiu St., 550012 Sibiu, Romania

⁶West Pomeranian University of Technology Dept. of Immunology, Microbiology, and Physiological Chemistry, Szczecin, Poland

Abstract

Emerging pollutants such as pharmaceutical active compounds were detected worldwide in different environmental compartments. Nowadays, multiple studies are focused on the investigation of their environmental fate, as well as to find new, efficient and sustainable removal technologies. Several studies demonstrated that heterogeneous photocatalysis is one of the most promising techniques used for water purification. Thus, the aim of our work was to evaluate the photodegradation efficiency of a refractory emergent compound, named clofibric acid, under UV light in aqueous solution. We report that photodegradation and mineralization efficiency are strongly dependent of the catalyst used. Results showed that the photodegradation was enhanced in the presence of TiO₂ Aeroxide. The complete elimination was achieved for an initial pollutant concentration of 1.5 mg/L after 30 min of irradiation, the degradation rate following the pseudo-first order kinetics. It was also observed that the rate constant for the photodegradation process is affected by the concentration of catalyst. Process efficiency is enhanced by increasing the light intensity. The simultaneous reduction of pollutant concentration and dissolved organic carbon demonstrates the mineralization of the target molecule. Furthermore, it was demonstrated that the addition of nitrate to the system increases the pollutant degradation rate, while the carbonate reduces its removal, suggesting that this last ion can act as a hydroxyl scavenger. Preliminary phytotoxicity tests were also carried out and showed the capacity of the heterogeneous photocatalysis to reduce the toxicity of reaction intermediates generated during the photocatalytic reaction.

Key words: degradation, kinetics, mineralization, nanosized catalysts, persistent micropollutant, photocatalysis

Received: July, 2018; Revised final: February, 2019; Accepted: May, 2019; Published in final edited form: August, 2019

* Authors to whom all correspondence should be addressed: e-mail: lidia.favier@ensc-rennes.fr, lacraistrati04@yahoo.com, asimion@ub.ro; Phone: +33223238135; Fax: +33223238020

1. Introduction

Nowadays, more and more, scientists and public organizations focus with an increased interest on the contamination of the aquatic environment by emergent organic pollutants, such as pharmaceutical molecules (e.g. anti-inflammatories, beta-blockers, antiepileptic drugs, painkillers, antibiotics, steroid hormones, blood lipid regulators, etc.) (Catrinescu et al., 2017; Gavrilesu et al., 2015; Hemidouche et al., 2018; Taieb et al., 2018; Ternes et al., 2004). This behavior is caused due to their continuous increasing consumption around the world, while having negative effects on humans health and aquatic life (i.e. acute toxicity, endocrine disruption or development bacterial resistance). Recently, this class of compounds was included in the Watch List of the 2013/39/EU Directive (Mestre et al., 2016). Various studies confirmed the occurrence of a great variety of pharmaceutical drugs and their metabolites in effluents and environmental waters due to the industrial activities, human consumption, or veterinary practices (Putschew et al., 2000; Ternes, 1998).

The present study focuses on the investigation of the photodegradation of clofibric acid, the main metabolite of clofibrate, a worldwide used lipid lowering drug. Clofibric acid (CFA) is one of the most often reported drug metabolite detected in the aquatic environment during the monitoring programs of pharmaceutical contaminants. Several studies reported the presence of this molecule in wastewater treatment plants (WWTP) (Andreozzi et al., 2003; Tauxe -Wuersch et al., 2005; Ternes et al., 1998), in the North Sea (Weigel et al., 2002) and even in drinking water (Boyd et al., 2003; Heberer, 2002) in concentration levels ranging from ng/L to µg/L.

This molecule is recognized as highly resistant to biodegradation (WWTP biomass or bacteria) and has high persistence in the environment (Gagne et al., 2006; Hemidouche et al., 2018). Hence, to date, the elimination of this molecule continues to be a subject of interest.

Heterogeneous photocatalysis is well recognized as one of the most promising techniques for the removal of refractory organic compounds from water (Cheriyann et al., 2017; Favier et al., 2015). Hence, the main objectives of this research are to: 1) investigate the photocatalytic degradation and mineralization efficiency of the target molecule in the presence of different commercial nanosized catalysts, 2) to examine the kinetics aspects related to the process (adsorption, photolysis and photocatalysis), 3) to analyze in detail the influence of some key operating parameters to enhance the reaction kinetics, 4) to determine the influence of the additional inorganic ions in the reaction system on the CFA degradation, and 5) to evaluate the viability of the process by assessing the toxicity of treated solutions.

2. Materials and methods

2.1. Materials and chemicals

Working solutions for the photocatalytic study and standards for the HPLC analysis of target compound were prepared with clofibric acid ($C_{10}H_{11}ClO_3$, > 99% of analytical purity) purchased from Acros Organics (New Jersey, USA).

Acetonitrile of HPLC grade and formic acid (LC/MS grade) were supplied by Fisher Chemical (U.K. Limited). Ultrapure water (18.2 MΩ·cm resistivity at 298 K, DOC < 5 µgC/L) used for the preparation of all aqueous solutions was produced by an ELGA Option-Q DV 25 water purifier system. For the photocatalytic degradation of CFA, different commercial titanium dioxides, namely, P25 Aeroxide (Acros Organics; New Jersey, USA; 80% anatase, 20% rutile; BET surface area 35-65 m²/g), Kronos uvp 7500 (Kronos Worldwide, Inc; 100% anatase; BET surface area > 225), and Cristal ACTIV PC500 (Cristal, France SAS; 100% anatase; BET surface area 350) were investigated and were used as received.

2.2. Experimental setup and procedure

To evaluate the photocatalytic activity of different catalysts and the influence of some process parameters (e.g. catalyst load, initial concentration of pollutant, light intensity, etc.), experiments were carried out in a cylindrical glass reactor with a capacity of 3 L and a working volume of 2 L (Fig. 1). A detailed description of the experimental device and of the strategy used to modulate the irradiation for the degradation tests is given in our previous work (Favier et al., 2015). Solution to be treated was artificially irradiated by using two UVA lamps (Sylvania, nominal power of 9 W) which are situated on the either side of the reactor.

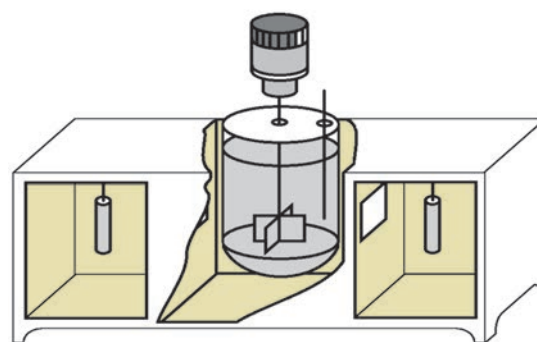

Fig. 1. Schematic representation of the experimental device used in this study

According to manufacturer's information, the spectral response of the used lamps is in the range 320-400 nm with a maximum emission at 365 nm which is suitable for the catalyst activation.

Before and during the photodegradation tests, the CFA solution containing the appropriate catalyst amount was continuously stirred by a mechanic stirrer to remain homogeneous. The assays were conducted in batch mode at room temperature (about 21 °C), with a stirring rate of 555 t/min and at natural pH (corresponding to the dissolution of CFA in water, 5.9). Prior to irradiation, the suspension was stirred in the dark for 60 min in order to achieve the adsorption/desorption equilibria of CFA on the semiconductor surface. It must be noticed that, before starting the irradiation experiments, the lamps were preheated for 30 min to attain the maximum intensity.

The photon flow per volume unit (in the range of 0.8-9.52 mW/cm²) was determined with a radiometer, VLX-3W (Vilbert Lourmat, Marne La Vallée, France). Samples were collected at different reaction times, centrifuged for 15 min at 10,000 rpm and filtered by using 0.22 µm syringe filters (Chromafil® Xtra H-PTFE; Macherey-Nagel, Germany) to separate the catalyst. Further, the prepared samples were used for HPLC analysis and dissolved organic carbon (DOC) determination as described in Section 2.3. All tests were carried out in duplicate and the experimental error was less than 5%.

2.3. Analytical procedures

Residual pollutant concentration was determined by high performance liquid chromatography (HPLC) using a WATERS® system equipped with a photodiode array detector (PDA; Waters™ 996). For analyte separation, a reversed phase column BEH C18 (250 mm x 4.6 mm, 5 µm) was employed. A mobile phase consisting of a mixture of 60/40 acetonitrile/ultrapure water containing 0.1% (v/v) of formic acid was used. Analysis was carried out in isocratic mode. The flow rate was 1 mL/min⁻¹ and the sample volume was 50 µL. The target compound was detected at 227 nm. Under these analytical conditions the retention time of CFA was 6.2 min.

A series of CFA standard solutions (5.6, 10, 20, 40, 60, 80 mg/L) were prepared in ultrapure water and used for quantification purpose. For the calibration curve, the obtained correlation coefficient (R^2) between the peak area and pollutant concentration was 0.998. Quantification and detection limits were calculated based on the study of Kadmi et al. (2015).

To evaluate the mineralization of the target molecule during the photocatalytic experiments, dissolved organic carbon (DOC) was measured by a TOC analyzer (Shimadzu TOC-5000-A, Shimadzu Corporation, Japan) coupled to a non-dispersive IR detector. Calibration and determination of DOC was carried out as earlier described by Favier et al. (2015). pH measurement was performed with a pH meter (Cyberscan Eutech Instruments; Thermo Fisher Scientific, Singapore) and a pH probe (VWR, France; 662-1775 series).

2.4. Toxicity assays

Lepidium sativum seeds were used to examine the toxicity of clofibric acid before and after the photocatalytic treatment. Root inhibition and germination tests were carried out according to ISO 11269-1:2012 standard with minor modifications. Briefly, seeds in two groups of 25 for each case were incubated in Duran Petri dishes (100*20 mm) for 24 hours at 23±2 °C. Seeds were evaluated, and germination counts were recorded. Afterwards, germinated seeds were transferred to new plates and incubated with the initial solution of clofibric acid, treated solution, or distilled water for comparison. The incubation at 23±2 °C lasted another 24 hours. Subsequently, remaining liquid was removed from each plate, and seeds were fixed for 60 min and stained with neutral red for other 10 min. Roots size was measured with a calliper.

2.5. Statistical analysis

Each dataset was analysed with ANOVA on Statistica 13 (Statsoft, USA) software. The results where $p < 0.05$ were considered statistically significant. The assumptions for the statistical analysis were checked for each inquiry.

3. Results and discussion

To investigate the photodegradation of the target molecule and for comparison purposes, experimental data obtained during the different kinetic studies were represented as pseudo first order kinetics (Eq. 1):

$$\ln\left(\frac{C_t}{C_0}\right) = -k_{ap} \times t \quad (1)$$

where: (k_{ap}) is the first order rate constant; (t) is the irradiation time in min; (C_t) is the residual concentration in CFA at reaction time t and (C_0) is the initial concentration of the pollutant in aqueous solution. Thus, the first order rate constant was calculated as the slope of the linear regression.

3.1. Investigation of photocatalytic potential of different titanium dioxide materials

To enhance the photodegradation efficiency of the target molecule, different commercial available titanium oxide catalysts, namely Kronos VLP 7000, P25 Degussa and PC500 (Cristal, France), were investigated. For this purpose, experiments were carried out under the same process conditions: an initial pollutant concentration of 30 mg/L and a catalyst dose of 1 g/L in agreement with the one reported in our previous studies (Favier et al., 2015, 2016a). For these tests a maximum irradiation, an initial pH of approx. 5.9 and a reaction time of 130 min were considered. Typical results related to the photocatalytic activity of the investigated catalysts are

presented in Fig. 2a and Fig. 2b. The data clearly show that TiO₂ Aeroxide P25 exhibits the highest photocatalytic activity in the removal of CFA. As shown in Fig. 2a, a photodegradation efficiency of about 85% was obtained in the presence of TiO₂ P25 for a reaction time of 130 min. However, the ability of the Kronos VLP 7000 and PC500 in CFA degradation was not higher than 43.54% and 26.08% after 130 min, respectively.

During the photodegradation process, the complete elimination of an organic molecule conduct to the formation of carbon dioxide and different inorganic anions and cations. Thus, in our work, in order to select the most efficient photocatalyst, the mineralization yield was also studied in terms of DOC reduction. From the Fig. 2b, it can be observed that in the presence of TiO₂ P25, the DOC removal efficiency is 26.33% for an irradiation time of 130 min. Under the same process conditions, the mineralization of CFA over the catalysts TiO₂ PC500 and Kronos VLP 7000 is lower than that of TiO₂ P25; DOC is reduced by 9.84% and 5.58% for TiO₂ PC500 and Kronos VLP 7000, respectively after the same reaction time.

Similarly, in their studies, Faisal et al. (2007) and Tariq et al. (2008) demonstrated that the photodegradation rate of dyes, chlorophenols and poly nitrophenols (Lacheb et al., 2008) was much higher in the presence of P25 as compared with other commercial catalysts.

According to literature, the difference in the photocatalytic activity is related to the variation in the BET surface, the presence of structural defects of the crystalline framework, impurities or to the hydroxyl groups density on the surface of catalyst (Ahmed et al., 2011). These parameters could affect the adsorption of pollutant on the catalyst surface, the reaction intermediates and also the recombination rate of electron hole pairs (Qamar et al., 2004).

Moreover, the high photocatalytic activity of P25 can be explained by its slow electron hole recombination rate and the morphology of its crystallites (Chatzitakis, 2008). Indeed, it was reported that the rutile/anatase combination promotes the

charge pair separation and inhibits recombination phenomena (Ahmed et al, 2011).

Therefore, all the results obtained in our work highlight the highest photocatalytic activity for P25 catalyst in the degradation of the target molecule. Thus, in this study, in all following photodegradation tests, titanium dioxide Degussa P25 was used.

3.2. Effect of UV irradiation, adsorption and photocatalysis

To highlight the effect of UV light/catalyst system on the elimination of clofibric acid, preliminary experiments were designed under different conditions: in the dark, in the presence of P25, we evaluated the contribution of the adsorption on the removal of the target molecule, with UV light in the absence of the catalyst to investigate direct photolysis of the pollutant. The tests were conducted at an initial pollutant concentration of 30 mg/L, a natural solution pH of 5.9, 1 g/L of catalyst and a maximal irradiation. The results obtained for the photodegradation efficiency are depicted in Fig. 3. In the dark, a very little loss in CFA (approx. 8%) was obtained after a reaction time of 190 min due to the adsorption of pollutant on the surface of catalyst. In addition, experimental data showed that the adsorption equilibrium is reached after a contact time of 1 hour (data not shown).

For the case when the pollutant was irradiated in the absence of catalyst, it was observed that UV light alone has a negligible effect on the degradation of the target molecule. Indeed, only a decrease of about 4% in CFA concentration was obtained for the same reaction time. Thus, these factors will be neglected in further photodegradation tests. These results are consistent with the ones previously reported by Favier et al. (2015, 2016a, 2016b) for carbamazepine and phenolic compounds. A similar behavior was reported by Quinores et al. (2015) for four recalcitrant pesticides with TiO₂ and B-doped TiO₂ catalysts and by Kamagate et al. (2017) for three fluoroquinolones antibiotics.

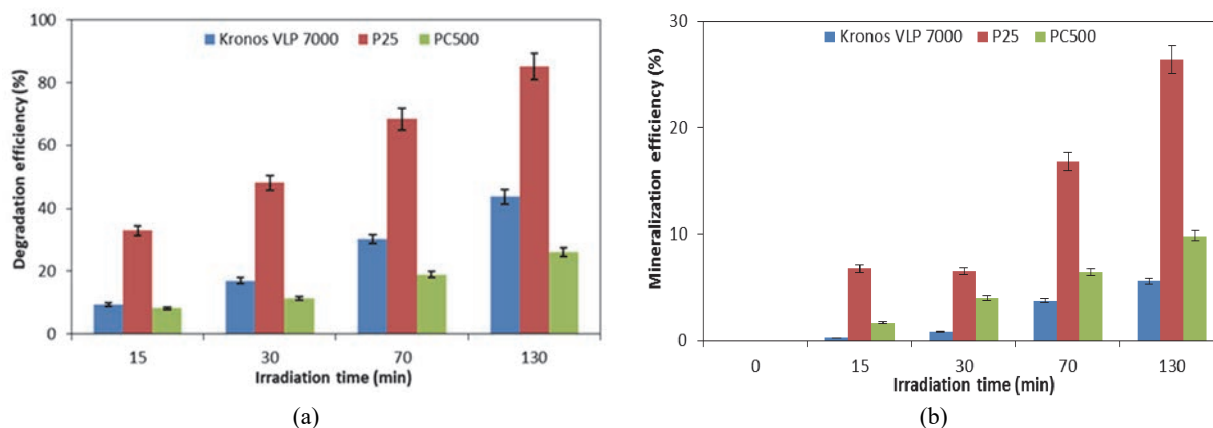

Fig. 2. Comparison of photocatalytic degradation (a) and mineralization (b) of CFA in the presence of different commercial photocatalysts. Experimental conditions: initial concentration in pollutant - 30 mg/L, concentration of commercial catalysts - 1 g/L, irradiation flux - 9.52 mW/cm², pH - 5.9

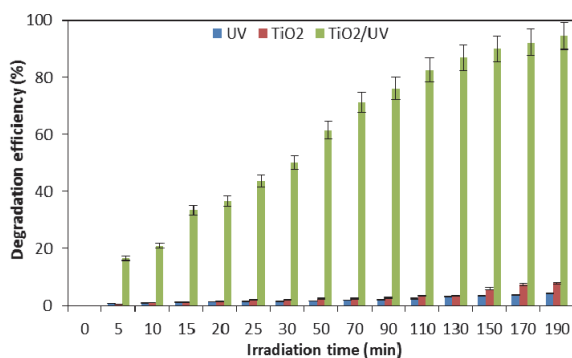

Fig. 3. Effect of photolysis, adsorption (TiO₂) and photocatalysis (TiO₂/UV) on the degradation of clofibric acid. Experimental conditions: pollutant concentration - 30 mg/L, catalyst (P25) concentration - 1 g/L, irradiation flux - 9.52 mW/cm², pH - 5.9

Moreover, our results showed that the photocatalytic treatment produces a significant degradation of the pollutant. Under these conditions, a decrease in CFA of about 95% was observed for a time period of 190 min. Thus, only UV light/P25 system improves the depletion rate of the target molecule.

3.3. Effect of initial pollutant concentration

To evaluate the successful application of the photocatalytic oxidation for the removal of CFA, it is of key importance to investigate how the initial pollutant concentration affects the degradation rate of the target compound. For comparison purposes, several photocatalytic degradation tests were carried out at different initial pollutant concentrations, ranging from 1.5 to 30 mg/L, to study the effect of this parameter. It should be noticed that, in this study, the used initial pollutant concentration was considered for analytical considerations related to HPLC and dissolved organic carbon measurements. According to literature data, even if the considered values for initial pollutant concentration are higher than the ones reported in water, it is supposed not to affect the photocatalytic degradation kinetics, the reaction mechanism or the reaction by-products (Santaballa et al., 2006). For these experiments, a catalyst concentration of 1 g/L and a maximal irradiation were used. The treatment efficiency was evaluated in terms of pseudo-first order kinetic data after a reaction time of 30 min. The obtained results demonstrated that the CFA photodegradations followed the first order kinetic model for all the investigated initial pollutant concentrations (Fig. 4).

The model is verified by the linear transformation ($-\ln(C/C_0) = f(t)$) and the calculated slopes give the apparent first-order rate constants (k_{app}). The calculated values for k_{app} indicated that the pollutant degradation rates decrease with the initial CFA concentrations (Fig. 5). It is important to point out that the equation indicated before cannot be employed for the experimental data above 30 min, due to the formation of reaction intermediates and their

competitive effect with the active site of catalyst. Thus, under these conditions the linear approach fails.

Data analysis showed a decrease of apparent rate constant from 0.077 to 0.024 min⁻¹ with the increase of initial concentration of pollutant from 1.5 mg/L to 30 mg/L. On the other hand, it was observed that by increasing the initial pollutant concentration, the total CFA removal efficiency decreases from 100% to 94.6% after 30 min of irradiation. Moreover, the extent of mineralization was also determined in terms of DOC reduction (data not shown). More than 70% of mineralization of CFA was obtained at 1.5 mg/L of CFA after a reaction time of 190 min.

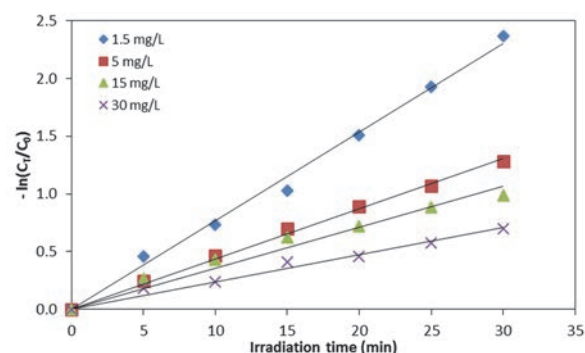

Fig. 4. Apparent first-order kinetics for clofibric acid for different initial pollutant concentrations. Experimental conditions: initial catalyst (P25) concentration - 1 g/L, irradiation flux - 9.52 mW/cm², natural solution pH - 5.9

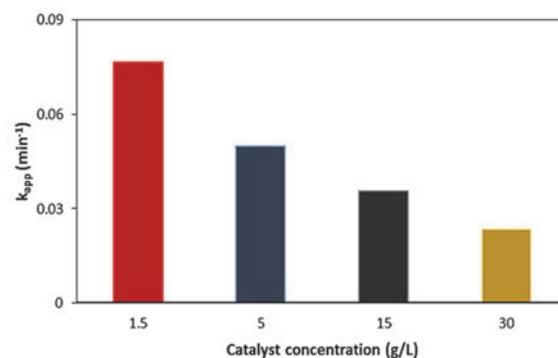

Fig. 5. Effect of initial concentration of pollutant on the apparent rate constants. Experimental conditions: initial catalyst (P25) concentration - 1 g/L, irradiation flux - 9.52 mW/cm², pH - 5.9

The inverse relation between CFA degradation and pollutant concentration can be explained by the fact that more reactants and intermediates were adsorbed on the P25 surface when CFA concentration increased. Thus, since the P25 dose, light irradiation flux and reaction time remain constant, a fewer number of active sites remain available for the generation of active species (hydroxyl radicals) needed for the pollutant degradation. Consequently, the CFA elimination rate decreases as the pollutant content increases due to the produced hydroxyl radicals which were the limiting reagents in the

degradation of the target molecule. In contrast, at a low pollutant concentration, the number of active catalytic sites is not a limiting factor anymore and the photocatalytic degradation rate is proportional to pollutant concentration according to the apparent first order kinetics (Selvam et al., 2007).

Sraw et al. (2014) showed a similar behavior for the degradation of the monochrotophos insecticide, using LR grade and P25 titanium dioxide catalysts under UV/sunlight irradiation conditions. Similar results were reported by Silva and Faria (2010) for the photocatalytic oxidation of four para-substituted phenols (4-chlorophenol, 4-aminophenol, 4-hydroxybenzoic acid and 4-nitrophenol) by using TiO₂ composite catalyst and P25 and by Ye et al. (2018) for the photodegradation metoprolol by TiO₂ arrays and UV-LED.

3.4. Effect of catalyst dosage

In a photocatalytic reaction, the degradation rate is strongly affected by the catalyst load. Several studies showed that for a heterogeneous photocatalytic process the reaction rate is proportionally to the catalyst dose and the optimal concentration is important to be determined to avoid the excess of catalyst and to ensure an efficient penetration of incident light into the reaction media (Abellan 2009; Daneshvar, 2003; Mendez-Arriaga et al., 2008). However, for high catalyst concentrations, an absorption photons loss could occur because of a light scattering phenomenon conducting to a decrease of the degradation rate (Favier et al., 2016; Silva and Faria, 2010). Thus, in the present study, we focused our attention on the study of the influence of this parameter. Photocatalytic experiments were carried out at 1.5 mg/L of CFA, a maximal irradiation flux and a natural solution pH. For these tests, the TiO₂ P25 concentration was varied from 0.1 g/L to 1 g/L. Fig. 6 gives the profile of the calculated rate constants as a function of catalyst load. Data analysis clearly indicated that the CFA degradation rate is increased by increasing the catalyst load. These findings are in agreement with our previous studies on the photocatalytic elimination of carbamazepine and hazardous phenolic compounds from aqueous suspensions (Favier et al., 2015, 2016a, 2016b). Similar results were reported earlier in literature for other emergent organic compounds (Ounnar et al., 2016a, 2016b; Verma et al., 2014).

Under the investigated experimental conditions, with the increase in semiconductor concentration from 0.1 g/L to 1 g/L, the apparent rate constants increased from 0.068 min⁻¹ to 0.105 min⁻¹, respectively. Our results confirm the positive role of the increased number of active sites on the photocatalytic process. Moreover, the calculated constants are lower than the one reported in the literature for CFA (Doll and Frimmel, 2004, 2005). A possible explanation is the photoreactor geometry and working conditions, especially to the used irradiation mode which influences the light transmission through

the solution and as a consequence, the incidence photon flux.

In addition, it was observed that 95.73% of CFA was eliminated for at 1 g/L of P25 min while only 87.63% of elimination was obtained for catalyst concentration of 0.1 g/L.

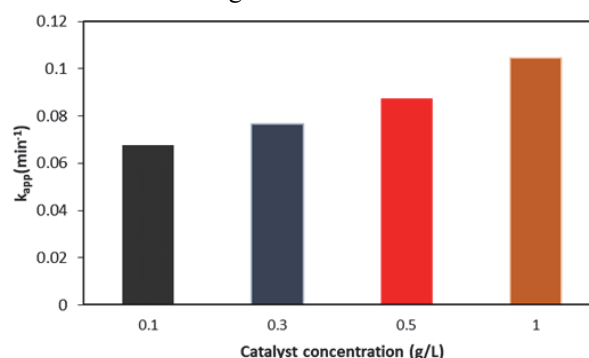

Fig. 6. Effect of catalyst concentration on the apparent rate constants. Experimental conditions: initial pollutant concentration - 1.5 mg/L, irradiation flux - 9.52 mW/cm², pH - 5

3.5. Effect of irradiation flux

In a photocatalytic process light intensity is another factor which determines the pollutant degradation efficiency (Pareek et al., 2008). Indeed, the photocatalytic degradation rate depends on the absorption of the UV radiation at surface of catalyst. The relation between this parameter and the photocatalytic degradation rate has been evaluated in different studies for various pollutants (Ahmed et al., 2011; Ho et al., 2011). It was reported that in water treatment, to achieve a high photocatalytic reaction rate, a relatively high light intensity is required to provide each active site on the catalyst surface with sufficient photons energy (Chong et al., 2010).

As this parameter plays an important effect on the photocatalytic degradation kinetics, in this work, additional tests were conducted at different incident light intensities to evaluate the influence of this parameter on the elimination of the target molecule. Fig. 7 depicts the profiles of the CFA degradation efficiencies obtained under the investigated conditions.

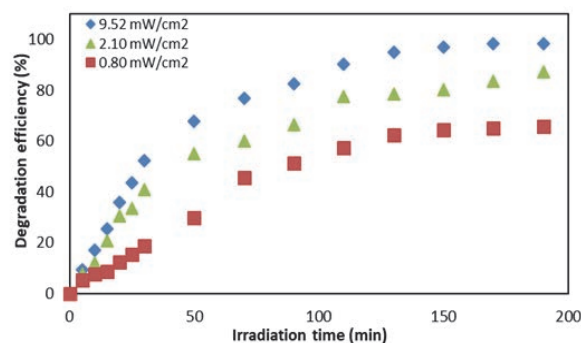

Fig. 7. Effect of the light intensity on the removal efficiency of the target molecule. Experimental conditions: initial pollutant concentration - 15 mg/L, catalyst (P25) concentration - 1 g/L, pH - 5.9

Data analysis shows that the removal yield of the studied compound increases with the UV light intensity. Up to 98.48% of CFA elimination was observed at an incident intensity of 9.52 mW/cm² after an irradiation time of 190 min, whereas, at 2.1 mW/cm² the measured degradation efficiency was only 87.3%. In addition, an elimination yield of 65.7% was found at a very low incident light flux (about 0.8 mW/cm²).

In their work, Das et al. (2014) studied the photodegradation of chlorhexidine on UV intensity. The authors also showed that the increase of light intensity conducted to an increase in the degradation rate of this molecule. Similarly, Qamar et al. (2006) reported an increase in the degradation rate with the increase of the light intensity in aqueous suspensions for the pesticides triclopyr and daminozid. In their work, Karunakaran et al. (2005), revealed the same behavior for the photooxidation of aniline on alumina with sunlight and artificial UV light.

3.6. Effect of inorganic ions

Considering the real life application of a photocatalytic process, the effect of inorganic ions on the degradation rate must be also taken into account. Generally, natural water and wastewater are very complex systems containing different anions (such as NO₃⁻, HCO₃⁻, Cl⁻) which may have a significant effect on the organic pollutants photooxidation even at very low concentration levels (Chong et al., 2010; Habibi et al., 2005). Therefore, to evaluate the photodegradation efficiency under conditions closer to the real ones, additional experiments were performed in order to investigate the influence of some inorganic ions on the degradation of clofibric acid. Two common ions, i.e. nitrate and carbonate ions (1 mM/L which is typical to wastewater effluent) were selected and added to CFA ultrapure water solutions (1.5 mg/L) containing 1 g/L of TiO₂ P25 prior to UV irradiation. The role of these inorganic ions on the degradation of target molecule is shown in Fig. 8. For comparison purposes results obtained without anions are also presented in the Fig. 8.

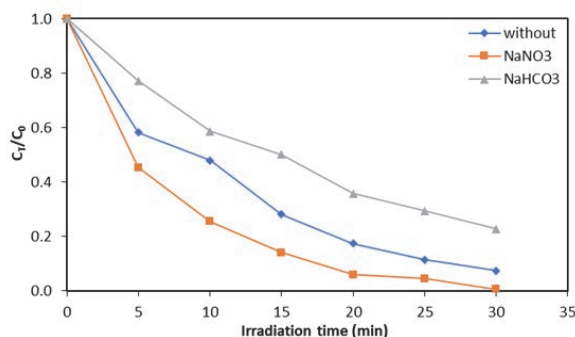

Fig. 8. Influence of different inorganic anions on the degradation efficiencies of clofibric acid by the UV/P25 process. Experimental conditions: initial pollutant concentration - 1.5 mg/L, catalyst (P25) concentration - 1 g/L, irradiation flux - 9.52 mW/cm², pH - 5.9

Data analysis shows, that the presence of NO₃⁻ has no detrimental effect on the UV/TiO₂ elimination of CFA. An increase in the pollutant degradation rate was obtained in the presence of NaNO₃ during the first 30 minutes of irradiation. According to experimental data, approx. 94% of CFA was photodegraded under these conditions. In their work, Neamtu et al. (2006, 2009) reported that the addition of NO₃⁻ accelerates the elimination rates of two endocrine disrupting compounds. Trovó et al. (2009) evaluated the photooxidation of sulfamethoxazole in different aqueous media indicating the positive influence of nitrate on the elimination of this molecule, indicating that such behavior could be explained by the fact that nitrate may also generate in solution strong oxidant species (hydroxide radical or singlet oxygen) enhancing the degradation efficiency. Vogna et al. (2004) found that the phototransformation of the antiepileptic drug, carbamazepine was enhanced by the addition of NO₃⁻ in the reaction media.

In addition, it was observed that the degradation efficiency of CFA significantly decreased with the addition of NaHCO₃ in solution. It is important to keep in mind that these results are in agreement with the ones reported in previous works (Habibi et al., 2005; Liu et al., 2015; Rioja et al., 2016). Indeed, it was found that for different AOP processes the ions carbonate and bicarbonate (HCO₃⁻ and CO₃²⁻) can act as •OH scavengers, reducing the reaction with the organic pollutant and as a consequence hindering their removal.

3.7. Toxicity assays

Different works reported the toxicity of the degradation intermediates generated during treatment of organic pollutants and pointed out their potential ecological risk. The formed reaction by-products could be more toxic than the parent molecules. Thus, during the photocatalytic degradation of CFA, different oxidation intermediates can be formed by the oxidation of the target molecule and can be present in the reaction media. For this reason, preliminary phytotoxicity tests were performed on dicotyl garden cress (*Lepidium sativum*) to evaluate if the UV/TiO₂ treatment shows any toxicity on the treated effluent. It must be pointed out that this specie is one of the most frequently employed in phytotoxicity assays. The main reason is their rapid ability of germination and growth (roots and shoots), as well as their sensitivity to low concentration of pollutants.

Different studies investigating the phytotoxicity of sewage sludge reported that during these tests the determination of roots lengths is more sensitive than the one of seed germination (Rizzo, 2011). For this reason, we chose to show in our paper only the results related to this parameter. For these experiments, the starting concentration of CFA was 30 mg/L. The photocatalytic experiment was carried out over 190 min at maximal irradiation and 1 g/L of catalyst.

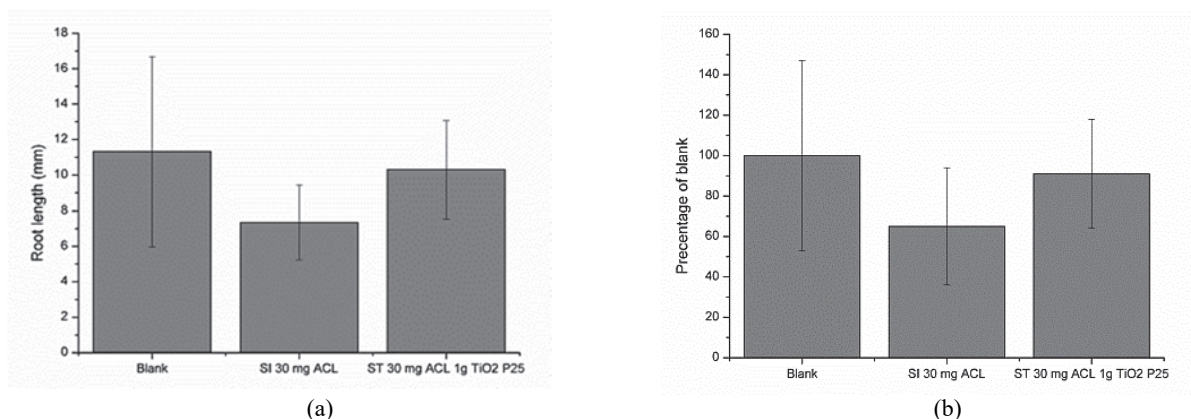

Fig. 9. Toxicity assessed by the root inhibition and germination tests in a CFA solution (30 mg/L) before and after the photocatalytic treatment using *Lepidium sativum* seeds: (a) measured root length; (b) calculated percentage of blank

For the phytotoxicity assay, samples of the endpoints resulted from three replicates ($n=3$) of UV/TiO₂ experiments were used. Results for the roots inhibition and germination tests of samples taken after 190 min of irradiation are given in Fig. 10. For clarity of results, we are reporting only the starting points and the ones collected at the end of the considered treatment period. Obtained data showed that the initial solution is more toxic than the treated one because of the high initial pollutant concentration. Indeed, the treatment with an initial solution of clofibrac acid of 30 mg/L caused significant decrease in root length ($p = 0.018$) within about 35% of inhibition compared to the control sample indicating that the presence of the pollutant in solution has an adverse influence of the evaluation of seeds germination. In their work, Migliore et al. (2003) also showed the negative influence of antibiotics on the root growth of several crop plants even at $\mu\text{g/L}$.

On the contrary, after the application of the photocatalytic process and an irradiation time of 190 min, the CFA solution showed no statistically significant difference with blank sample containing only distilled water ($p = 0.993$) suggesting that the photocatalytic treatment after the considered reaction time considerably reduces the accumulation of toxic reaction intermediates in the reaction media.

As previously stated (Section 3.2), the addition of catalyst in the reaction media and the irradiation enhance the oxidation of the target molecule resulting in an increase of the removal efficiency. This implies that the same mechanism could occur in the TiO₂/UVA system with the resulted by-products in the later stage of the treatment. These results are in good agreement with the ones reported by Rosal et al. (2009) for catalytic and non-catalytic ozonation of aqueous solutions of clofibrac acid. However, more bioassays tests (using for example *Daphnia magna* and *Vibrio fischeri*) are needed to assess the biological potency of the treated effluent and to confirm the efficiency of such technique in the removal of the toxicity of the parent compound and its reaction intermediates.

4. Conclusions

Overall, the results presented in this study confirm that UV/TiO₂ process can be a promising alternative for the efficient elimination of clofibrac acid, a pharmaceutical molecule well-known for its persistence in the aquatic environment and for its refractory character through biological elimination. The investigated commercial catalysts showed a contrasted efficiency in the removal of the target molecule. It was found that the TiO₂ Aeroxide P25 significantly enhances the elimination of this molecule. It was also observed that process parameters affect the photocatalytic reaction playing an important role in the CFA degradation and have even opposite effects on the process efficiency. Indeed, the percentage of pollutant elimination increases when initial pollutant concentration decreases (1.5 mg/L). In parallel, the experimental results clearly showed that the catalyst load and UV irradiation have a positive influence on the photodegradation. It was also observed that the oxidation of CFA with the UV/TiO₂ process fits with the apparent first-order kinetics model. The DOC reduction after a reaction time of 190 min (about 70%) confirmed the mineralization of this refractory organic molecule and this process efficiency. However, an increase of reaction time would lead to an increase in the mineralization degree of these molecules. Moreover, the study on the addition of some anions frequently found in wastewater effluents allowed us to understand their effect on the pollutant elimination. Results indicate that the addition of NO₃⁻ in the reaction media enhances the CFA elimination efficiency, while the HCO₃⁻ decreased its photodegradation.

The photocatalytic process reduces the toxicity of the treated effluent. The irradiated solutions collected after an irradiation time of 190 min have no significant effect on seeds germination and roots growth. All these data demonstrate that the advanced oxidation process based on the use of UVA/TiO₂ system represents a promising technique for water purification.

Acknowledgements

R.M. Hlihor acknowledges the support received by the Romanian National Authority for Scientific Research and Innovation, CNCS/CCCDI – UEFISCDI, under the project PN-III-P4-ID-PCE-2016-0683, Contract no. 65/12.07.2017.

References

- Abellan M.N., Gimenez J., Esplugas S., (2009), Photocatalytic degradation of anti-biotics: the case of sulfamethoxazole and trimethoprim, *Catalysis Today*, **144**, 131-136.
- Ahmed S., Rasul M.G., Martens W.N., Brown R., Hashib M.A., (2011), Advances in Heterogeneous photocatalytic degradation of phenols and dyes in wastewater: A review, *Water, Air and Soil Pollution*, **215**, 3-29.
- Andreozzi R., Raffaele M., Nicklas P., (2003), Pharmaceuticals in STP effluents and their solar photodegradation in aquatic environment, *Chemosphere*, **50**, 1319-1330.
- Boyd G.R., Reemtsma H., Grimm D.A., Mitrac S., (2003), Pharmaceuticals and personal care products (PPCPs) in surface and treated waters of Louisiana, USA and Ontario, Canada, *Science of Total Environment*, **311**, 135-149.
- Catrinescu C., Chelba A., Teodosiu C., Apopei P., (2017), Removal of diclofenac from secondary wastewater effluents by Fenton based processes, *Environmental Engineering and Management Journal*, **16**, 765-777.
- Chatzitikis A., Berberidou C., Paspaltsis I., Kyriakou G., Sklaviadis T., Poulis L., (2008), Photocatalytic degradation and drug activity reduction of chloramphenicol, *Water Research*, **42**, 386-394.
- Cheriyani A.J., Shaik F., Baawain M.S.A., Sarkar J.P., (2017), A study on the removal of contaminants from secondary treated municipal wastewater by solar photocatalysis, *Environmental Engineering and Management Journal*, **16**, 1451-1456.
- Chong M.N., Jin B., Chow C.H.W., Saint C., (2010), Recent developments in photocatalytic water treatment technology: a review, *Water Research*, **44**, 2297-3027.
- Daneshvar N., Salari D., Khataee A.R., (2003), Photocatalytic degradation of azo dye Acid Red 14 in water: Investigation of the effect of operational parameters, *Journal of Photochemistry and Photobiology A*, **157**, 111-116.
- Das R., Sarkar S., Chakraborty S., Choi H., Bhattacharjee C., (2014), Remediation of antiseptic components in wastewater by photocatalysis using TiO₂ nanoparticles, *Industrial Engineering and Chemistry Research*, **53**, 3012-3020.
- Doll T.E., Frimmel F.H., (2004), Kinetic study of photocatalytic degradation of carbamazepine, clofibric acid, iomeprol and iopromide assisted by different TiO₂ materials – determination of intermediates and reaction pathways, *Water Research*, **38**, 955-964.
- Doll T.E., Frimmel F.H., (2005), Removal of selected persistent organic pollutants by heterogeneous photocatalysis in water, *Catalysis Today*, **101**, 195-202.
- Faisal M., Tariq M.A., Muneer M., (2007), Photocatalysed degradation of two selected dyes in UV-irradiated aqueous suspensions of titania, *Dyes and Pigments*, **72**, 233-239.
- Favier L., Simion A.I., Rusu L., Pacala M.L., Grigoras C., Bouzaza A., (2015), Removal of an organic refractory compound by photocatalysis in batch reactor – a kinetic study, *Environmental Engineering and Management Journal*, **14**, 1327-1338.
- Favier L., Simion A. I., Matei E., Grigoras C.G, Kadmi Y., Bouzaza A., (2016a), Photocatalytic oxidation of a hazardous phenolic compound over TiO₂ in a batch system, *Environmental Engineering and Management Journal*, **15**, 1059-1067.
- Favier L., Harja M., Simion A.I., Rusu L., Kadmi Y., Pacala M.L., Bouzaza A., (2016b), Advanced oxidation process for the removal of chlorinated phenols in aqueous suspensions, *Journal of Environmental Protection and Ecology*, **17**, 1132-1141.
- Gagné F., Blaise C., André C., (2006), Occurrence of pharmaceutical products in a municipal effluent and toxicity to rainbow trout (*Oncorhynchus mykiss*) hepatocytes, *Ecotoxicology and Environmental Safety*, **64**, 329-336.
- Gavrilescu M., Demnerová K., Aamand J., Agathos S., Fava F., (2015), Emerging pollutants in the environment: present and future challenges in biomonitoring, ecological risks and bioremediation, *New Biotechnology*, **32**, 147-156.
- Habibi M.H., Hassanzadeh A., Mahdavi S., (2005), The effect of operational parameters on the photocatalytic degradation of three textile azo dyes in aqueous TiO₂ suspensions, *Journal of Photochemistry and Photobiology A: Chemistry*, **172**, 89-96.
- Heberer T., (2002), Occurrence, fate, and removal of pharmaceutical residues in the aquatic environment: a review of recent research data, *Toxicology Letters*, **131**, 5-17.
- Hemidouche S., Favier L., Amrane A., Dabert P., Le Roux S., Sadaoui Z., (2018), Successful biodegradation of a refractory pharmaceutical compound by an indigenous phenol-tolerant *Pseudomonas aeruginosa* strain, *Water, Air and Soil Pollution*, **229**, 1-16.
- Ho D., Vigneswaran S., Ngo H.H., Shon H.-K., Kandasamy J., Chang C.-Y., Chang J.-S., (2011), Photocatalysis of trimethoprim (TRI) in water, *Sustainable Environmental Research*, **21**, 149-154.
- Kadmi Y., Favier L., Harja M., Simion A.I., Rusu L., Wolbert D., (2015), A new strategy for pentachlorophenol monitoring in water samples using ultra-high performance liquid chromatography - mass spectrometry tandem, *Environmental Engineering and Management Journal*, **14**, 567-574.
- Kamagate M., Assadi A.A., Kone T., Coulibaly L., Hanna K., (2017), Activation of persulfate by irradiated laterite for removal of fluoroquinolones in multi-component systems, *Journal of Hazardous Materials*, **346**, 159-166.
- Karunakaran C., Senthilvelan S., (2005), Photooxidation of aniline on alumina with sunlight and artificial UV light, *Catalysis Communications*, **6**, 159-165.
- Lachheb H., Houas A., Herrmann J.-M., (2008), Photocatalytic degradation of polynitrophenols on various commercial suspended or deposited titania catalyst using artificial and solar light, *International Journal of Photoenergy*, doi: 1155/2008/497895.
- Liu N., Sijak S., Zheng M., Tang L., Xu G., Wu M., (2015), Aquatic photolysis of florfenicol and thiamphenicol under direct UV irradiation, UV/H₂O₂ and UV/Fe(II) processes, *Chemical Engineering Journal*, **260**, 826-834.
- Mendez-Arriaga F., Esplugas S., Gimenez J., (2008), Photocatalytic degradation of non-steroidal anti-inflammatory drugs with TiO₂ and simulated solar irradiation, *Water Research*, **42**, 585-594.

- Mestre A.S., Nabiço A., Figueiredo P.L., Pinto M.L., M. Soledade M., Santos C.S., Isabel M. Fonseca I.M., (2016), Enhanced clofibric acid removal by activated carbons: water hardness as a key parameter, *Chemical Engineering Journal*, **283**, 1384-1391.
- Migliore L., Cozzolino S., Fiori M., (2003), Phytotoxicity to and uptake of enrofloxacin in crop plants, *Chemosphere*, **52**, 1233-1244.
- Neamtu M., Frimmel F.H., (2006), Photodegradation of endocrine disrupting chemical nonylphenol by simulated solar UV-irradiation, *Science of Total Environment*, **369**, 295-306.
- Neamtu M., Popa D.M., Frimmel F.H., (2009), Simulated solar UV-irradiation of endocrine disrupting chemical octylphenol, *Journal of Hazardous Materials*, **164**, 1561-1567.
- Ounnar A., Bouzaza A., Favier L., Bentahar F., (2016a), Macrolide antibiotics removal using a circulating TiO₂-coated paper photoreactor: parametric study and hydrodynamic flow characterization, *Water Science and Technology*, **73**, 2627-2637.
- Ounnar A., Favier L., Bouzaza A., Bentahar F., (2016b), Kinetic study of spiramycin removal from aqueous solution by heterogeneous photocatalysis, *Kinetics and Catalysis*, **57**, 200-206.
- Pareek V., Chong S., Tade M., Adesina A., (2008), Light intensity distribution in the heterogeneous photocatalytic reactors, *Asia Pacific Journal of Chemical Engineering*, **3**, 171-201.
- Putschew A., Wischnack S., Jekel M., (2000), Occurrence of triiodinated X-ray contrast agents in the aquatic environment, *Science of the Total Environment*, **255**, 129-134.
- Qamar M., Muneer M., Bahnemann D., (2006), Heterogeneous photocatalysed degradation of two selected pesticide derivatives, triclopyr and daminozid in aqueous suspensions of titanium dioxide, *Journal of Environmental Management*, **80**, 99-106.
- Qamar M., Saquib M., Muneer M., (2004), Semiconductor-mediated photocatalytic degradation of an azo dye, chrysoidine Y in aqueous suspensions, *Desalination*, **171**, 185-193.
- Rioja N., Zorita S., Penas F.J., (2016), Effects of water matrix on photocatalytic degradation and general kinetic modeling, *Applied Catalysis B: Environmental*, **180**, 330-335.
- Rizzo L., (2011), Bioassays as a tool for evaluating advanced oxidation process in water and wastewater treatment, *Water Research*, **45**, 4311-4340.
- Rosal R., Gonzalo M.S., Boltes K., Leton P., Vaquero J.J., Garcia-Calvo E., (2009), Identification of intermediates and assessment of ecotoxicity in the oxidation products generated during the ozonation of clofibric acid, *Journal of Hazardous Materials*, **172**, 1061-1068.
- Santaballa J.A., Maskill H., Canle M.L., (2006), *The Relationship Between Mechanism and Rate Law*, In: *The Investigation of Organic Reactions and their Mechanisms*, Maskill H. (Ed.), Blackwell Publishing Ltd., Wiley-Blackwell, pp. 79-103.
- Selvam K., Muruganandham M., Muthuvel I., Swaminathan M., (2007), The influence of inorganic oxidants and metal ions on semiconductor sensitized photodegradation of 4-fluorophenol, *Chemical Engineering Journal*, **128**, 51-57.
- Silva C.G., Faria J.L., (2010), Photocatalytic oxidation of phenolic compounds by using a carbon nanotube-titanium dioxide composite catalyst, *ChemSusChem*, **3**, 609-618.
- Sraw A., Wanchoo R.K., Toor A.P., (2014), Optimization and kinetic studies for degradation of insecticide monocrotophos using LR grade and P25 TiO₂ under UV/sunlight conditions, *Environmental Progress and Sustainable Energy*, **33**, 1201-1208.
- Taieb S., Imen N., Nizar B., (2018), Degradation of chlorothiazide in acidic aqueous solution by electro-Fenton process, *Environmental Engineering and Management Journal*, **17**, 1411-1416.
- Tariq M.A., Faisal M., Saquib M., Muneer M., (2008), Heterogeneous photocatalytic degradation of an anthraquinone and a triphenylmethane dye derivative in aqueous suspensions of semiconductor, *Dyes and Pigments*, **76**, 358-365.
- Tauxe-Wuersch A., de Alencastro L.F., Grandjean D., Tarradellas J., (2005), Occurrence of several acidic drugs in sewage treatment plants in Switzerland and risk assessment, *Water Research*, **39**, 1761-1772.
- Ternes T.A., (1998), Occurrence of drugs in German sewage treatment plants and rivers, *Water Research*, **32**, 3245-3260.
- Ternes T.A., Joss A., Siegrist H., (2004), Scrutinizing pharmaceuticals and personal care products in wastewater treatment, *Environmental Science and Technology*, **38**, 393A-399A.
- Trovó A.G., Nogueira R.F., Agüera A., Sirtori C., Fernández-Alba A.R., (2009), Photodegradation of sulfamethoxazole in various aqueous media: Persistence, toxicity and photoproducts assessment, *Chemosphere*, **77**, 1292-1298.
- Verma A., Prakash N.T., Toor A.P., (2014), Photocatalytic degradation of herbicide isoproturon in TiO₂ aqueous suspensions: study of reaction intermediates and degradation pathways, *Environmental Progress and Sustainable Energy*, **33**, 402-408.
- Vogna D., Marotta R., Andreozzi R., Napolitano A., d'Ischia M., (2004), Kinetic and chemical assessment of the UV/H₂O₂ treatment of antiepileptic drug carbamazepine, *Chemosphere*, **54**, 497-505.
- Weigel S., Kuhlmann J., Hühnerfuss H., (2002), Drugs and personal care products as ubiquitous pollutants: occurrence and distribution of clofibric acid, caffeine and DEET in the North Sea, *Science of Total Environment*, **295**, 131-141.
- Ye Y., Feng Y., Bruning H., Yntema D., Rijnaarts H.H.M., (2018), Photocatalytic degradation of metoprolol by TiO₂ nanotube arrays and UV-LED: Effects of catalyst properties, operational parameters, commonly present water constituents, and photo-induced reactive species, *Applied Catalysis B: Environmental*, **220**, 171-181.